

C- 50

Persiana enrollable de aluminio perfilado con lamas curvas de 50 mm, relleno de espuma de poliuretano para un mayor aumento de la densidad de la persiana

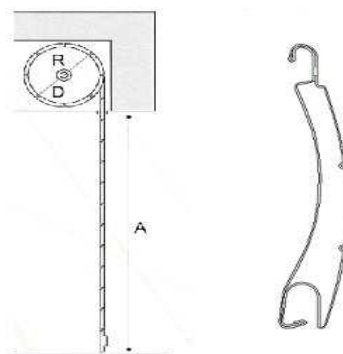

CARACTERÍSTICAS TÉCNICAS TECHNICAL CHARACTERISTICS

ESPESOR NOMINAL NOMINAL THICKNESS	8,9mm
ALTURA DE CUBRIMIENTO COVERING SURFACE	50 mm
Nº DE LAMAS POR M.L. DE ALTURA Nº OF SLATS PER LINEAL METRE HEIGHT	20
MEDIDAS MÁXIMAS DE USO MAXIMUN USABLE SIZE	275 x 300
PESO POR M2 WEIGHT PER SQUARE METRE	2.7 kg
UNIDAD DE EMBALAJE METRES PER BOX	288 ml.
LARGO DE PRODUCCIÓN MANUFACTURING LENGTH	5.50 a 6.50 ml.
DIÁMETRO DE ENROLLAMIENTO ROLL DIAMETER	Eje Ø 40/60 mm.

CONSEJOS PARA ACCIONAMIENTOS ÓPTIMOS ADVICED SYSTEMS TO INSTALL SHUTTERS

RECOGEDOR CINTA STRAP COILER	Hasta / Up to 3 m2
TORNO A CABLE WINCH BY CABLE	Hasta / Up to 5 m2
TRANSMISIÓN MANIVELA WINCH BY HANDLE	Hasta / Up to 7m2
MOTORIZACIÓN TUBULAR MOTOR	Hasta / Up to 8 m2

Persiana enrollable
de aluminio perfilado

C-50

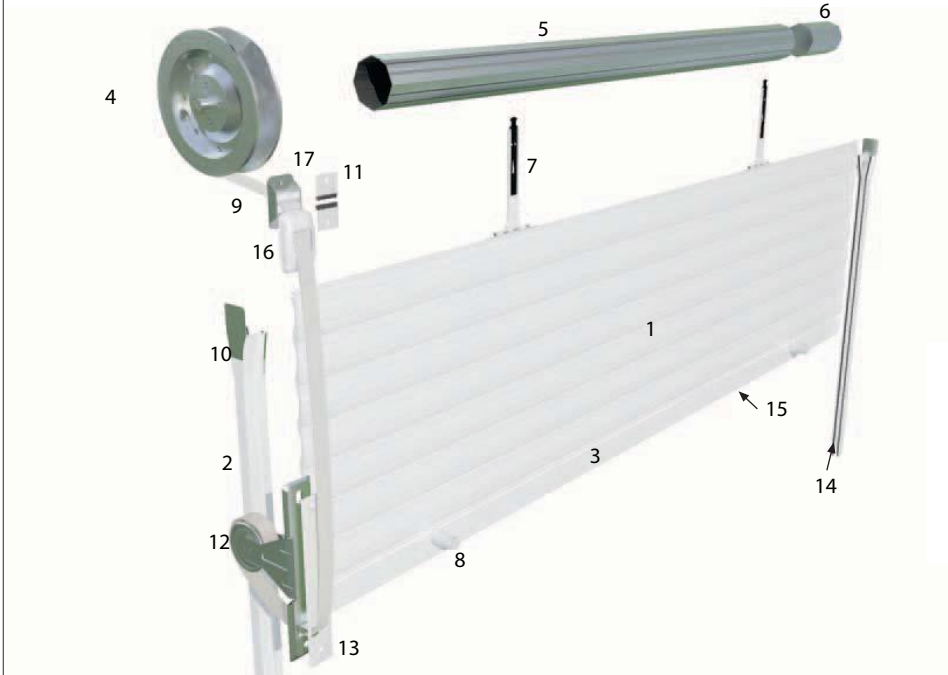

1 Lama C-50



2 Guías Z-25



3 Terminal PTA



4 Disco 150 x 60 R - Cinta 22



5 Eje Metálico 60 x 0.4 R



6 Cápsula Metálica 60 R



7 Tirantes Mixtos



8 Topes 40



10 Embudos guía Z-25



9 Cinta 22



11 Cepillo Térmico



12 Recogedor Metálico Milan cinta 22



13 Placa Ancha Aluminio Milan



14 Felpa en Guía Z-25



16 Carcasa Aluminio

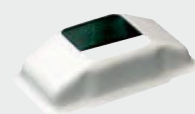

15 Felpa en Terminal PTA



17 Pasacintas Metálico cinta 22

